

MermaidTM
Crafted shower and wall panels

Crafted by us, designed by you.

We believe we have created a product that is a choice not a compromise. A product that fulfils all the requirements of tiles but with none of the stress.

A product that is so versatile it will fit beautifully into any bathroom, whatever your chosen style, leaving you able to design and create your ideal space...

The Ranges

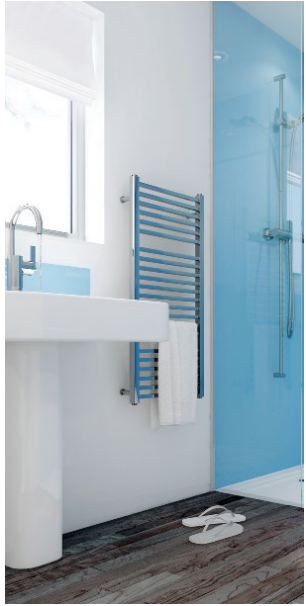

Glass

Sheet sizes:

Bespoke

Sheet Thickness:

6mm

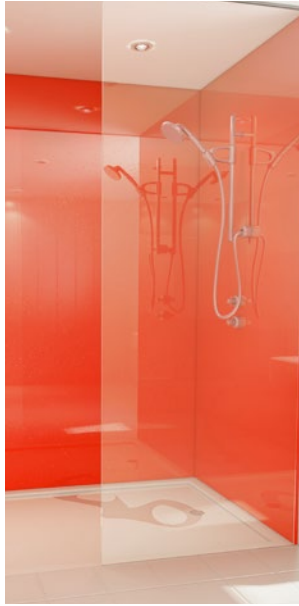

Acrylic

Sheet sizes:

2400 x 600mm

2400 x 900mm

2400 x 1200mm

Sheet Thickness:

4mm

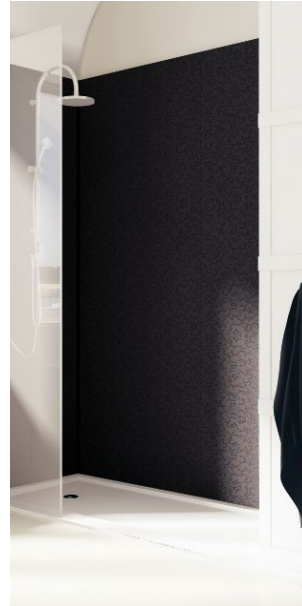

Artisan

Sheet sizes:

2400 x 585mm T&G

2400 x 900mm SQ

2400 x 1200mm SQ

Sheet Thickness:

11mm



Traditional

Sheet sizes:

2400 x 585mm T&G

2400 x 900mm SQ

2400 x 1200mm SQ

Sheet Thickness:

11mm



Modern

Sheet sizes:

2400 x 585mm T&G

2400 x 900mm SQ

2400 x 1200mm SQ

Sheet Thickness:

11mm



Natural

Sheet sizes:

2400 x 585mm T&G

2400 x 900mm SQ

2400 x 1200mm SQ

Sheet Thickness:

11mm

We've split our range into six different categories. All our products have all the Mermaid benefits, but we've arranged them according to their style. Hopefully one will be a perfect match for you and your bathroom.

How it works

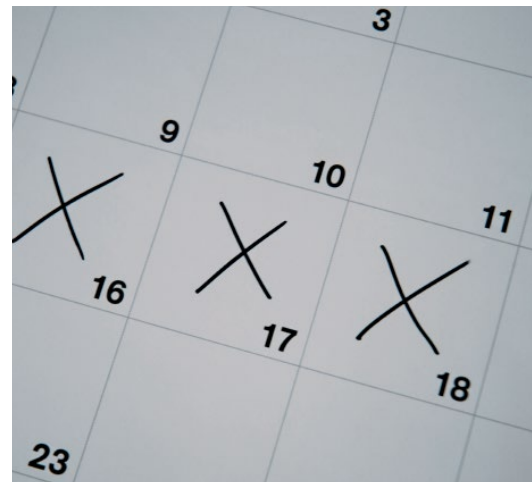
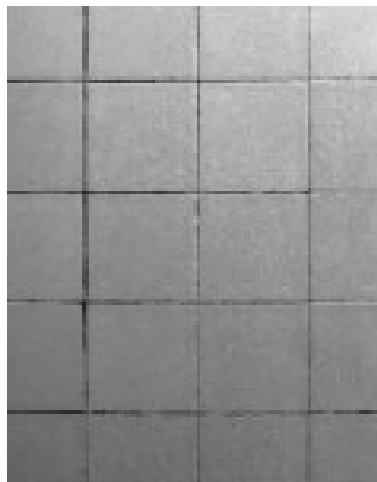

Saving

That's the long and short of it - on average it'll be 25% cheaper than installing tiles, and generally it'll be even lower than that still. This is mainly because Mermaid panels do not require a specialist tiler. As an addition to this Mermaid panels last much longer than tiles further saving on the full life cost.

No More Mould

We're fed up of grout, it takes a long time to apply, it's a nightmare to clean and after a while it just goes mouldy. There's no grout used with our panels, so that means no more mould.

Extra Time

Mermaid panels are so much quicker to fit than tiles that it'll save you money and the effort of getting someone in for long periods of time. Of course it also means that you'll be without your bathroom for a lot less time, which is great. We don't have anything against tilers though, so if you do want to use one, you can, it just won't take them as long to fit a Mermaid panel as a wall of tiles.

Clean & Safe

A selection of our panels are now available in our patented **Mermaid Antibacterial Coating**. This is incorporated into the panel during the production process and means once bacteria comes into contact with the surface the bacteria basically die. Look out on the colours pages to see which panels are available.

10
year

Watertight Guarantee

The Mermaid panel system is guaranteed to remain watertight and waterproof for ten years from date of purchase. For full terms and conditions see www.mermaidpanels.com

What is a Mermaid Panel?

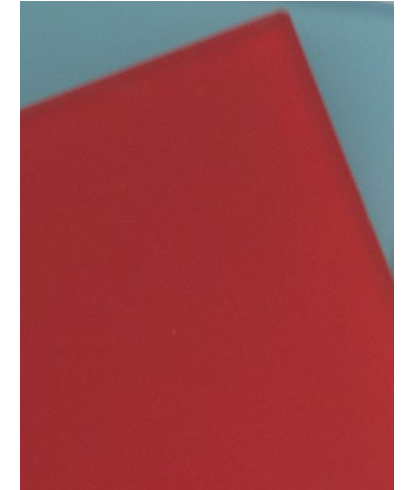

Laminated Front

High Pressure Laminate (HPL) is then bonded to the plywood using a PVA (D4 rated) adhesive system to give a completely waterproof surface meeting all the requirements of EN438.

Balancing laminate

A balancing laminate is bonded to the reverse of the panel also using PVA adhesive system this ensures the panels structural stability and minimises bowing or twisting.

Wooden Core

The panel substrate is 9mm WBP (Weather and Boil proof) plywood which is water resistant and meets the requirements of EN635.

Glass

Mermaids glass panels are produced in 6mm toughened glass in a range of standard colours, further colours are available by special request. After the special painting process the back of the panels are protected using a vinyl film to both prevent damage and stop light transition through the panel.

Acrylic

Originally developed as a cost effective alternative to painted glass our Acrylic panels are a highly engineered polymer, enhanced with colour. They have higher heat distortion than conventional polymers (up to 100° Celsius) which means it has more applications and scratches can also be polished out.

High Pressure Laminate

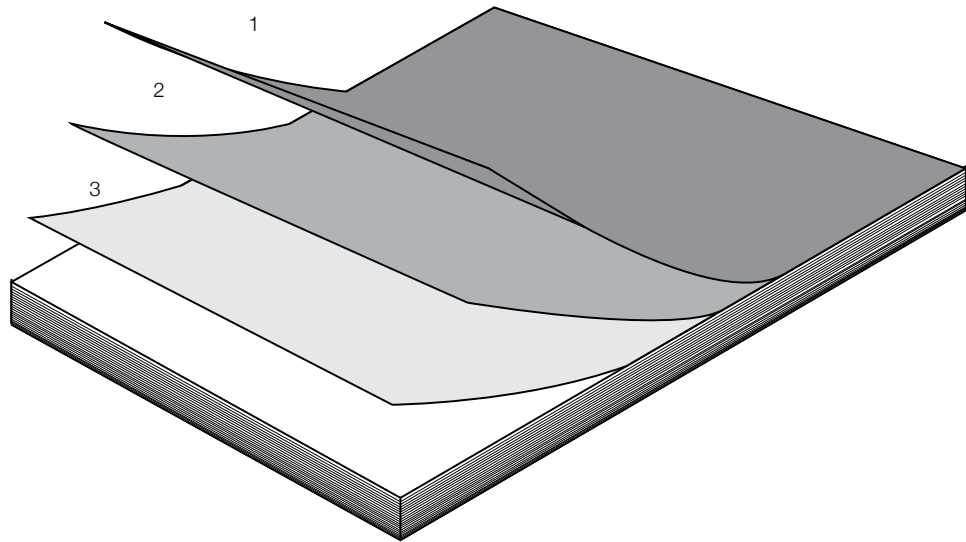

The Sheet

High pressure decorative laminates are ready-finished man made veneers of high density. They consist of layers of specially selected papers impregnated with thermosetting synthetic resins, fused together under heat and very high pressure.

A sheet is built up as follows:

- 1- A protective, transparent layer of alpha cellulose paper impregnated with melamine formaldehyde for resistance to stains, heat, impact and abrasion.
- 2- A decorative printed sheet impregnated with a melamine formaldehyde resin for strength, colour-fastness and clarity.
- 3 - the core, of layers of kraft paper impregnated with phenolic resin strength and flexibility in the finished laminate.

Heat

Decorative laminates will withstand surface temperatures of up to 180C (363F) for short periods without deterioration of surface or colour, although in some cases a slight loss of gloss may occur, but continuous localised heat must be avoided.

High pressure laminates are resistant to steam and boiling water and are therefore ideal for applications where cleanliness and hygiene are important factors.

Performance	Chemical
No effect after 16 hours contact.	Acetic acid, acetone, ammonia, alcohol, amyl acetate, benzene, butyl acetate, carbon tetrachloride, caustic soda (solutions less than 10%), citric acid, detergents, olive oil, paraffin, phenol, petrol, soaps, sugar solutions, toluene, xylene.
No effect if completely removed within 10-15 minutes.	Caustic soda (solutions greater than 10%), ferric chloride, formic acid, hair dyes, hypochlorite bleach, hydrochloric acid (less than 10%), hydrogen peroxide (less than 30%), iodine, nitric acid (less than 10%), oxalic acid, phosphoric acid (less than 10%), potassium permanganate, silver nitrate, sulphuric acid (less than 10%)
Permanent staining probable; requires immediate removal.	Hydrochloric, nitric, phosphoric and sulphuric acids in concentrations greater than 10%.

Chemicals

The above chart indicates the performance of laminates when in contact with various sample chemicals.

Mermaid and the Environment

According to BREEAM, laminated panels significantly outperform all others due to the following reasons:



Life Span

Mermaid's panels are engineered and guaranteed for 10 years which is significantly greater than alternative materials, this further reduces the need to replace as frequently hence less need for production with the obvious environmental effect.



Shipping

The majority of Mermaids materials are sourced from the UK and Northern Europe to ensure that shipping distances are minimised, this together with the lower material weight and lower production energy requirements helps reduce the carbon footprint of the materials



Sustainability

Core materials are all taken from PEFC (Program for the Endorsement of Forest Certification) and FSC (Forest Stewardship Council) accredited sources. When buying it is 100% assured that you are not contributing to the destruction of the world's forest. The accreditation also ensures the appropriate ethical approach to political, economic, social, environmental and global warming factors.



Thermal Insulation

Laminated panels feel much warmer than tiles and have a significantly lower u value (Thermal insulation) 3.4 typically compared to 5.9 (tiles). The effect of this is the room loses less heat and is therefore more efficient.



BREEAM

Environmental assessment method for buildings, which sets standard for sustainable design and buildings environmental performance. BREEAM is a scientific evidence-based research which drives its on-going development

How we build

We like to think we've got a factory of craftsmen, all skilled and all proud of what they send out - with very good reason.

All our plywood is sourced from PEFC and FSC certified sustainable forests.



Welcome to the Jungle

Over the years we have worked out that there is a risk that the pre-bonded laminate may bow if the air is too dry, so using our moisture control system we maintain our factory at precise temperature and humidity levels. Although we're proud of this innovation it does mean that the air in the factory is more akin to the rainforests of Borneo than the north coast of England.

Timing

Like most good things in life, when making our panels, timing is everything. Once the ply has had adhesive applied we've just eight minutes to get the laminated face applied then it's rushed into the press. 16 Megapascals of force is then applied making sure both sides are perfectly bonded.



How we build



Check Please

Despite the fact that we use our brand spanking new machine to apply the joint, when our panels have a tongue and groove applied our guys still check by hand to make sure the joint is perfect.



Sticky Situation

It's taken us a while to work out the exact levels of adhesive required to perfectly bond our laminate to the plywood. Too much and it runs from the side, too little and it won't work at all. The machine above places the laminate on the rollers after it's dried. We know that it's perfect because it's picking the sheets up faultlessly.



Cutting Through

After our panels are bonded, the edges are cut using our bespoke designed multi-headed routing machine, which produces a perfect square edge or locking joint. After rotating the panels through 180 degrees the top and bottom of the panels are also machined to produce the all important engineered bottom profile, this holds the extra sealant which ensures a perfect seal at the base of the panel.



Glass

Using glass modernises any space and can make your shower panels become the focus of any room.

Tough, beautiful and available in over 30 colours our glass



Glass



Panels in Porcelain Blue Glass

The beauty of our glass product, is not just the clean lines and colours, it's the products versatility. Shown here in blue it perfectly complements the dark wood floors and white walls, but with over 30 other colours to choose from you really can let your imagination run wild.

The glass is our newest and most technically advanced product, for this reason we will supply a professional fitter to survey and install.

Glass Colours and Patterns

Mermaid glass panels are split into three different price bands, 1 to 3. 1 is the least expensive, 3 the most.

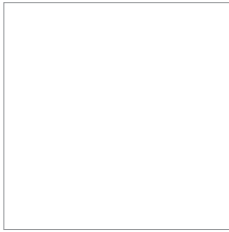

Pure White 2

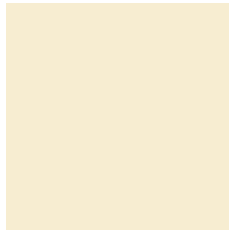

Oatmeal 2



Light Grapefruit 2

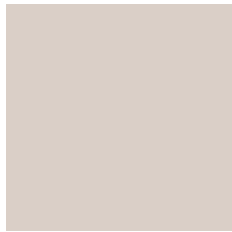

Antelope 2

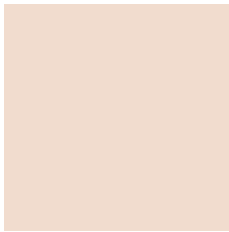

Pampas 2



Copper Metallic 3



Star Galaxy Metallic 3

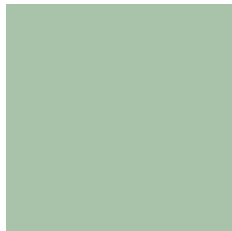

Mineral Green 1

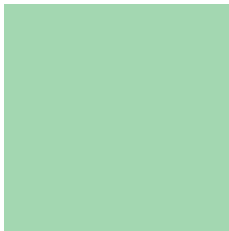

Pastel Green 1



Light Emerald Metallic 3



Kiwi 2



Grecian Spa 1



Sky Blue Metallic 3

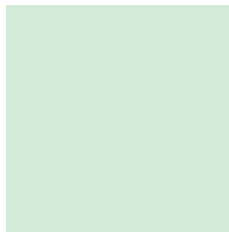

Glacial Green 1

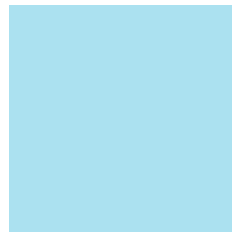

Porcelain Blue 1



Sapphire Blue Metallic 3



Blue Jeans 2



Azure Blue 1

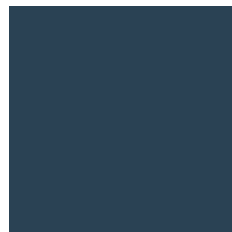

Charcoal Grey 1

All colours are representative - we recommend you ring for a sample before ordering.



Sunshine Metallic 3



Golden Maize 1



Bright Orange 2



Lipstick 1

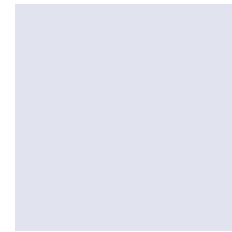

Pale Lavender 2

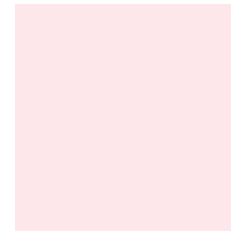

Clover Pink 2

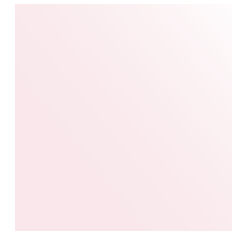

Rose Pink Metallic 3



Dusky Pink 1



Fuchsia 2



Purple Red 1



Regal Violet 1



Shiraz 2

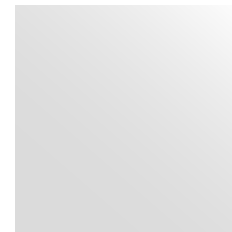

Silver Metallic 3



Light Aircraft Grey 2



Truffle 1



Chocolate 1



Dove Grey 1



White Aluminium 1



Graphite Grey Metallic 3



Jet Black 1

Acrylic

Our new Acrylic range is the perfect balance of style and convenience, available in 12 beautiful solid colours, the panels offer a very modern look but with the bonus of being incredibly easy to install.



Acrylic



Sheet sizes:

2400 x 600mm
2400 x 900mm
2400 x 1200mm

Sheet Thickness:

4mm

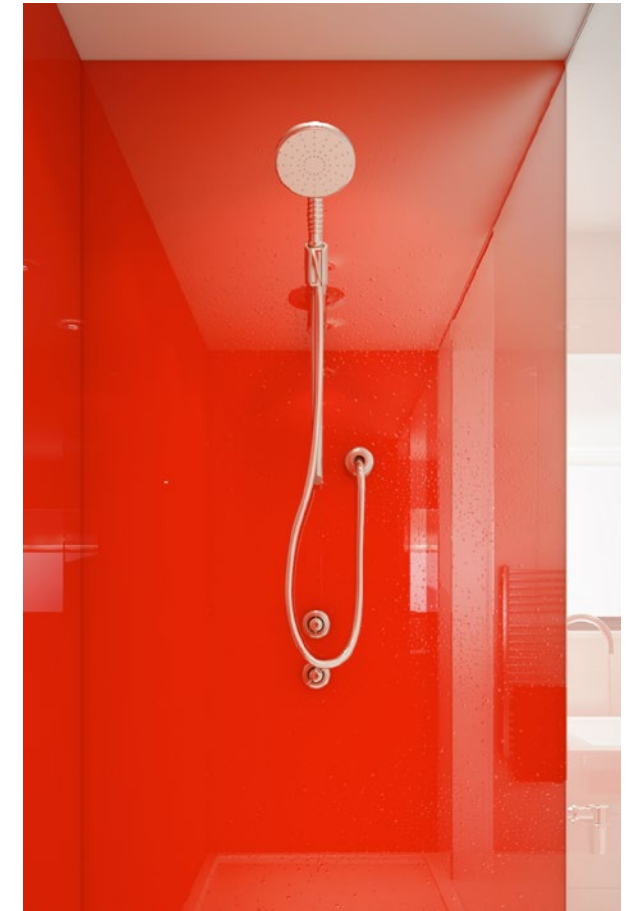

Panels in Crimson

The ultimate modern wall panel and the perfect cost effective alternative to glass. Our Acrylic panels are an environmentally friendly, highly engineered polymer, enhanced with colour.

Shown here in Crimson they make the perfect feature wall for any bathroom.

Acrylic Colours

All colours are representative - we recommend you ring for a sample before ordering.
Mermaid Acrylic panels are split into two price bands, E1 and E2. E1 is the least expensive, E2 the most.



Acrylic White Ice

E2

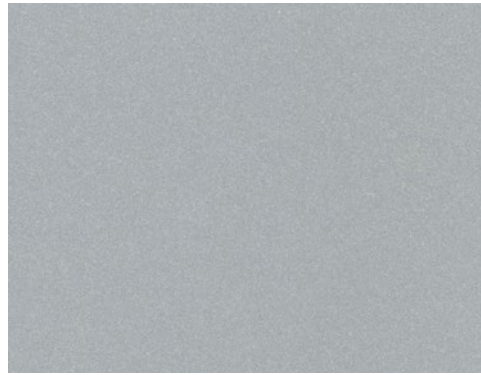

Acrylic Silver Ice

E2

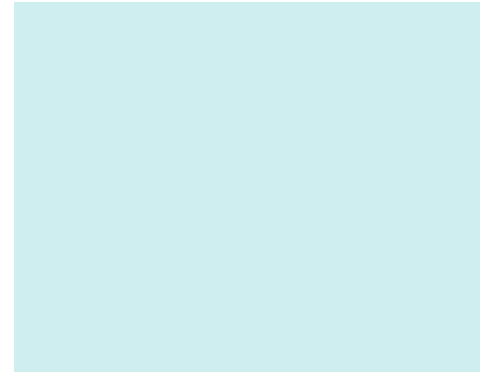

Acrylic Mist

E1



Acrylic Aqua

E1

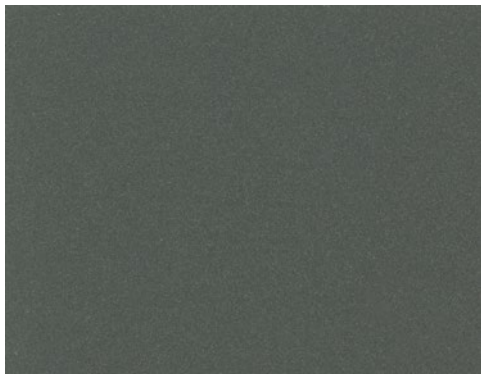

Acrylic Black Ice

E2

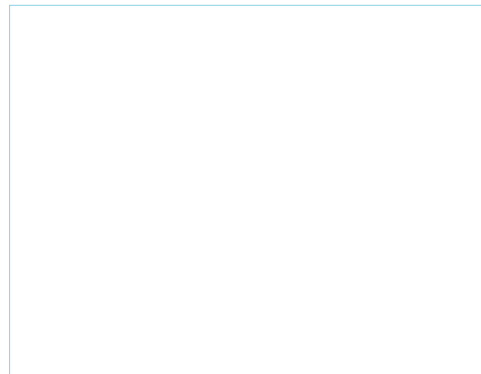

Acrylic White

E1



Acrylic Plum

E1



Acrylic Forest Green

E1

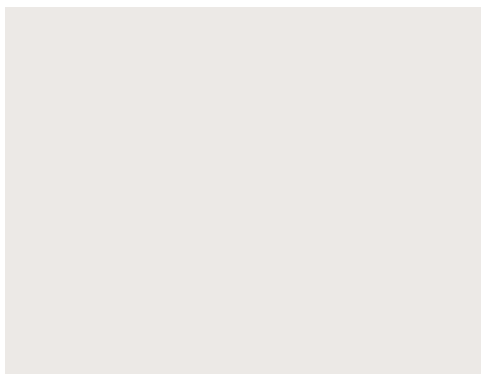

Acrylic Vanilla

E1

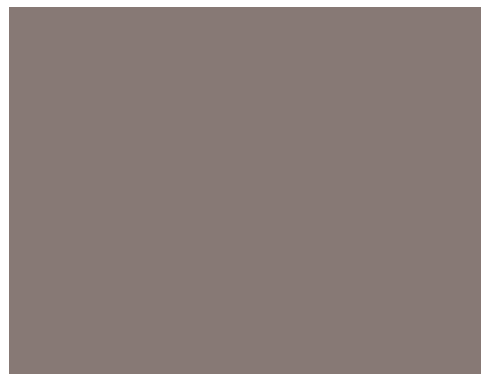

Acrylic Coffee

E1



Acrylic Crimson

E1

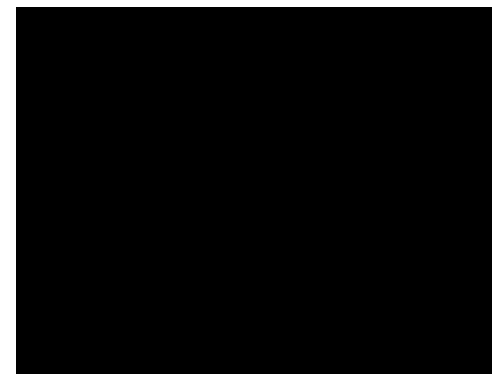

Acrylic Black

E1

Artisan

Our Artisan range has been created for those who truly want to make a statement. It's been designed to compliment both traditional and modern spaces, and can be used as a bold focal point of a room or as a subtle link to other features.

We think of the range as being closer to classic wallpaper designs than tiles, thus matching traditional interior design with the innovation of Mermaid, beautifully.



Artisan



Panels in Dark Lace

With the classic bathroom fittings and the wooden details around the window, the pattern gives a further sense of tradition whilst at the same time offering a unique sense of design.

Sheet sizes:

2400 x 585mm T&G

2400 x 900mm SQ

2400 x 1200mm SQ

Sheet Thickness:

11mm

Artisan Colours and Patterns

Mermaid panels are split into four different price bands, A to D. A is the least expensive, D the most. All colours are representative - we recommend you ring for a sample before ordering.



Orchid Violet

D

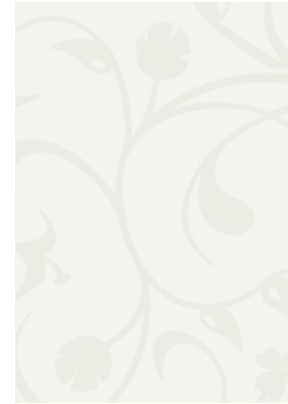

Orchid White

D



Orchid Black

D

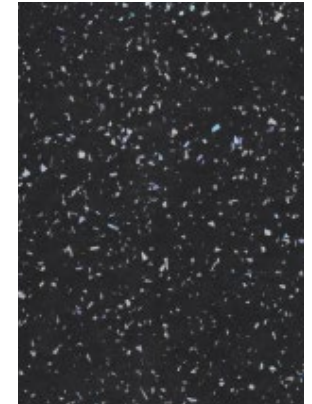

Night Sky

D

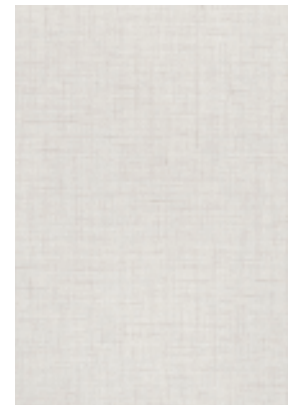

White Linen *

C



Eggshell Linen *

C



Grey Linen *

C

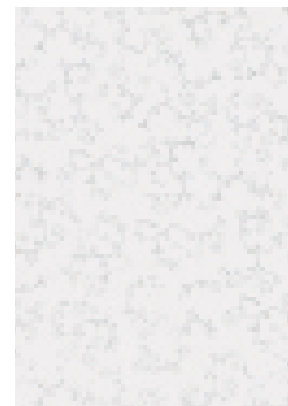

White Lace

D

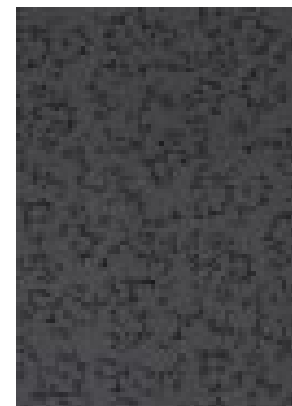

Dark Lace

D



Virage

C

Traditional

The patterns and colours in our traditional range are some of our most popular. These are patterns you would most associate with shower and wall panelling - classic, yet contemporary designs.

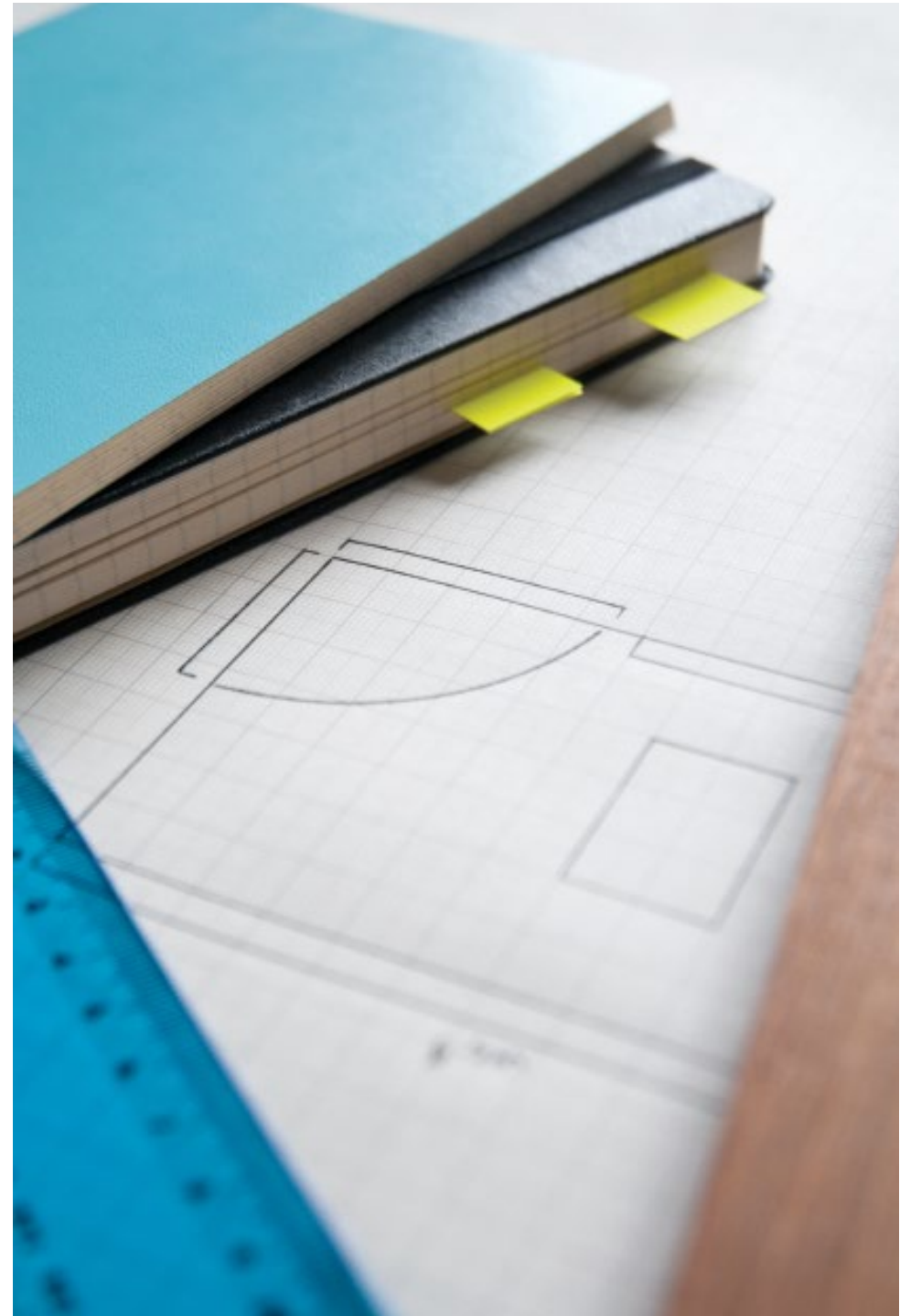

Traditional



Panels in Snow Lustre

Using Mermaid you will be surprised at how easily and quickly a room can be converted from a standard space to a bathroom and any wall can become 100% waterproof.

Here the iridescent Snow Lustre shower panels complement the rest of the room without detracting from the beautiful traditional features.

Sheet sizes:

2400 x 585mm T&G

2400 x 900mm SQ

2400 x 1200mm SQ

Sheet Thickness:

11mm

Traditional



Panels in Sorrento Marble

A traditional look does not have to be boring, classic white bathroom furniture is set off by the stunning Sorrento Marble finish for a look that is both timeless and modern.

Traditional Colours and Patterns



Water Crystal *

A



Snow Lustre *

A

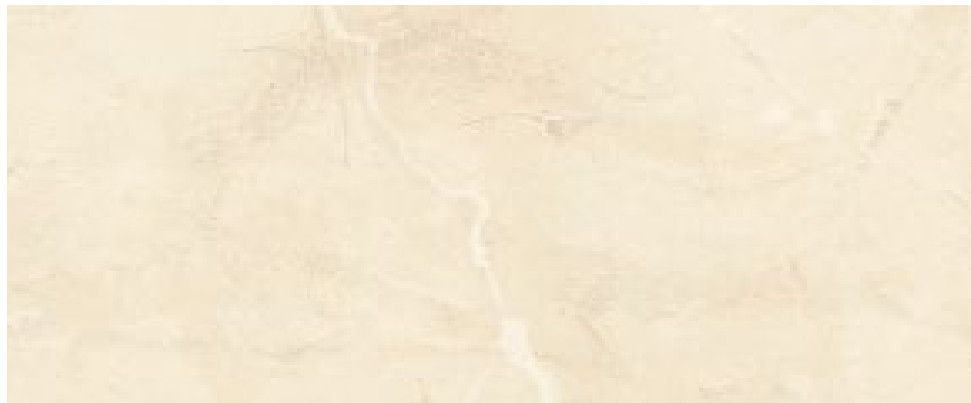

Sorrento Marble *

A

Mermaid panels are split into four different price bands, A to D. A is the least expensive, D the most. All colours are representative - we recommend you ring for a sample before ordering.



Cream Amber

C



Snowdrift *

B

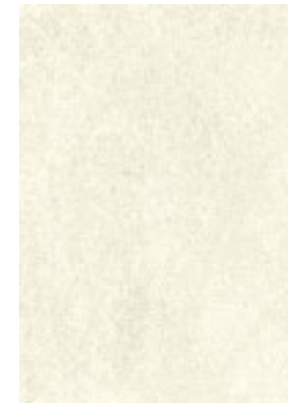

Ermine *

B



Waters Edge *

A

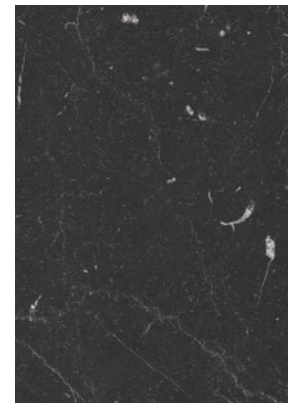

Burgos Marble *

A

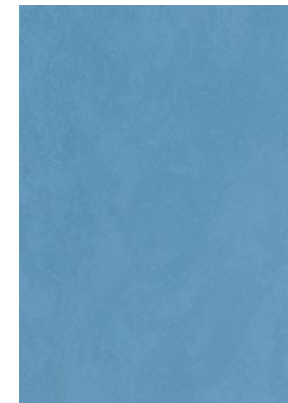

China Blue *

B



Mint Frost

B

Modern

Our Modern range is designed to enliven even the most standard of bathrooms. Using modern technical designs and materials, such as concrete, your bathroom can be brought straight into the twenty first century.



Modern



Panels in Concrete

A full wall of concrete not only perfectly fits within the modern space it sits, but also blends beautifully with the tiled floor.

Sheet sizes:

2400 x 585mm T&G
2400 x 900mm SQ
2400 x 1200mm SQ

Sheet Thickness:

11mm

Modern Colours and Patterns

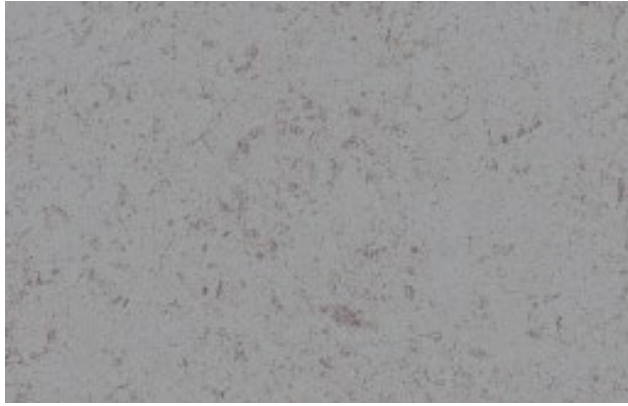

Quicksilver C



Jet Argent C

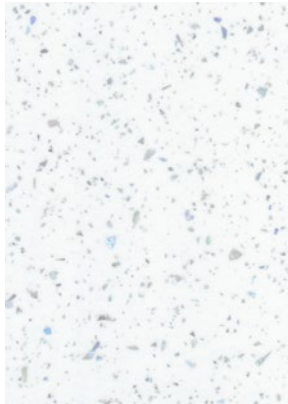

Constellation C



Concrete C



Copper B



Inca Stone A



Ferrite B



Pearl Crush B

Mermaid panels are split into four different price bands, A to D. A is the least expensive, D the most. All colours are representative - we recommend you ring for a sample before ordering.



Carnelian Gold * C

*** Available in Mermaid's patented Antibacterial finish. See how it works for information.**

Super Gloss

These finishes are manufactured using a specific 1.0mm laminate that has an increased 0.3mm thickness to ensure that the face has an extremely high gloss.

The product is a great lower cost alternative to glass, albeit with a much smaller colour range.

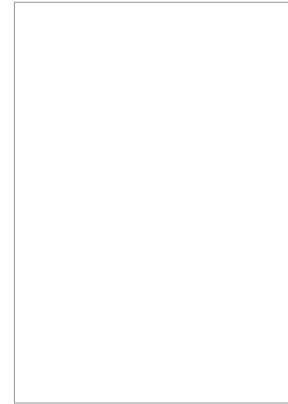

Quartz White * A



Super Gloss Black C

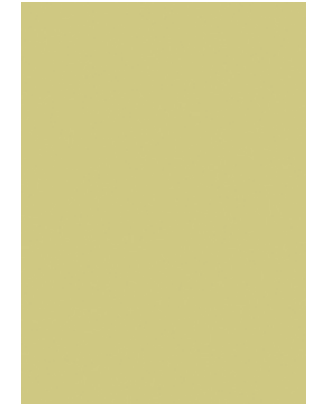

Super Gloss Olive C

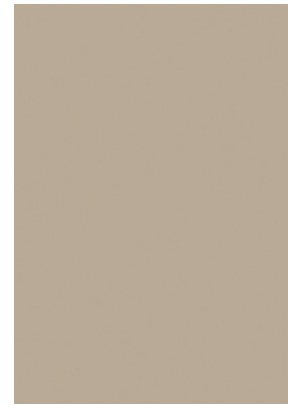

Super Gloss Beige C



Super Gloss Purple C



Super Gloss Red C

Natural

The beauty of nature, matched with the ease and intelligence of Mermaid.
Our natural range is perfect for those who want the look of natural materials but with all the benefits of Mermaid.



Natural

Sheet sizes:

2400 x 585mm T&G

2400 x 900mm SQ

2400 x 1200mm SQ

Sheet Thickness:

11mm

Panels in Milanese Stone

A classic colourway of pale blue and white is brought to life using the earthy Milanese stone.



Natural Colours and Patterns



Firecoat

C



Travertine

B



Roman Stone *

B



Nebula

C



Slate

B



Sandstone

A

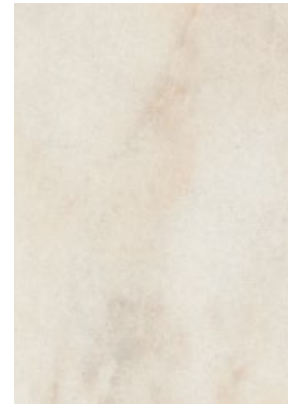

Verona *

A

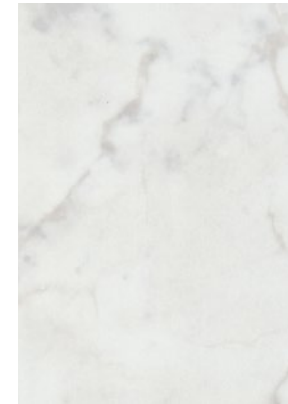

Egyptian Marble

A



Feather Marble *

A



Milanese Stone *

B



Lava Stone *

A

Mermaid panels are split into four different price bands, A to D. A is the least expensive, D the most. All colours are representative - we recommend you ring for a sample before ordering.

* Available in Mermaid's patented Antibacterial finish. See how it works for information.

Vanities

Perfect if you want a bespoke solution for your vanity surface, that can perfectly match your shower and wall panels.

Available in laminate, solid surface and glass in a huge range of colours, we aim to match any colour or finish you require to complete your perfect bathroom.

Let your creative juices flow, either call or email and our design team will be happy to advise and help.



Shown to the right a glass vanity in Pastel Green, every colour from our huge glass range is available in our vanity units. To the left a Solid Surface vanity in Gloss White.

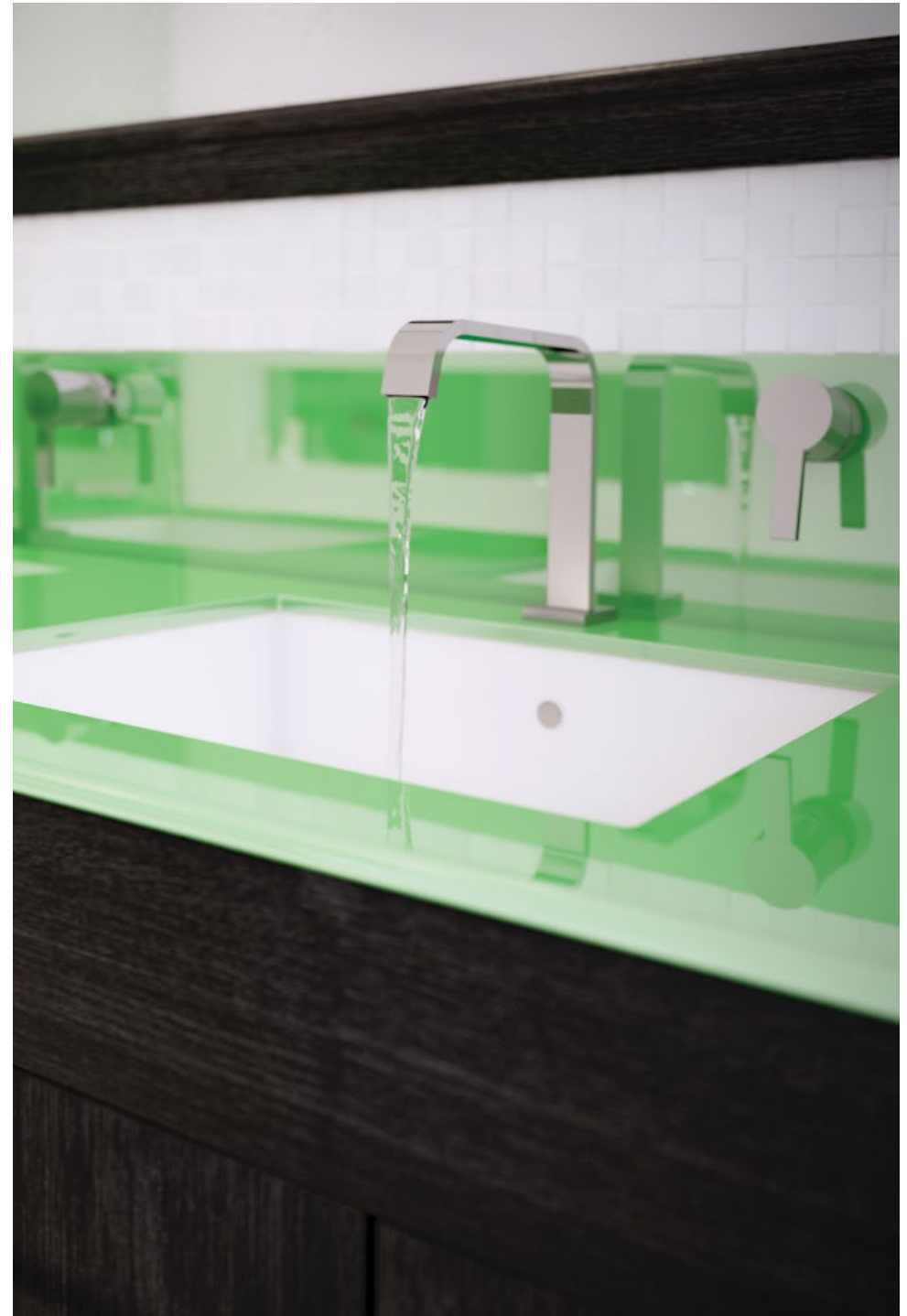

Adaptation

Using our panels any bathroom can easily be adapted to turn a bath area to an easy access shower - the wall is now guaranteed waterproof.



Panels in Waters Edge

Using the panels to adapt a traditional bathroom not only creates a new waterproof space, but the classic colours used in Waters Edge perfectly match the existing space.

Architectural

Our panels are not just for the home and the bathroom - they are perfect for a number of architectural and commercial applications.



Panels in Super Gloss Beige and Quartz White

The clean contemporary lines typical of modern interior design are perfectly reflected in our new gloss panels.

Fitting

Mermaid panels are designed so that any competent tradesperson should be able to fit them.

Over the next few pages there are our top tips before setting out and the basic steps to fixing the panels.

Comprehensive fitting instructions are provided with every order and can also be downloaded directly from our web site at www.mermaidpanels.com

Our products can be purchased as complete kits to ensure that you get all items required to complete your installation (excluding screws and fixings). A check list for each kit can be found on the inside back cover of this brochure.

Tips

1. Cutting the panels

For best results the cutting action should always be into the decorative face of the panel. So when using a fine toothed handsaw, make sure the decorative side is faced upwards. When using a jigsaw or circular saw, the decorative face should be downwards. When cutting holes for valves and pipes, a minimum of 2mm clearance should be allowed all the way around. This clearance must be filled with silicone sealant.

2. Preparing the walls

Mermaid panels can be fixed to most surfaces including concrete, chipboard and existing tiles, but it is important to ensure the walls are even and sound in order to provide the best possible fixing for them. When adhesive is to be used, clean and dry the walls to ensure the most effective bond. Note the primary fixing method used should always be mechanical, i.e. by the use of screws and rawplugs depending on the structure of the substrate.

3. Fittings

Shower attachments and other fittings can be secured directly to Mermaid panels using the appropriate fixings.

4. Tools

No specialist equipment is required, just normal woodworking tools. Such as a wood saw, screwdriver, sealant gun, spirit level, tape measure, drill, etc...

Transeal bottom seal system

Features

Adaptive movement joint to ensure constant seal between shower tray and panel base.

Utilises specially formulated silicone to achieve highest possible bond strength.

Joint flexibility allows tray to deflect up to 10mm whilst under load and ensures a guaranteed leak free joint.

Plan of corner joint

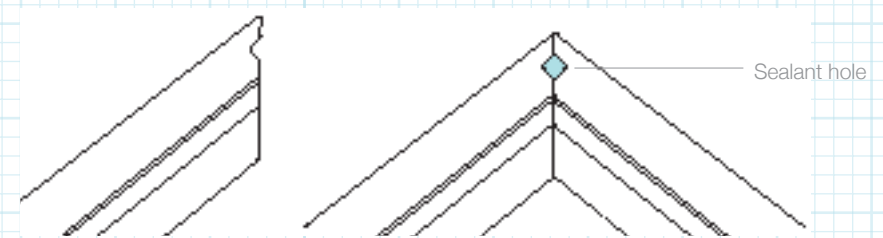

Side elevation

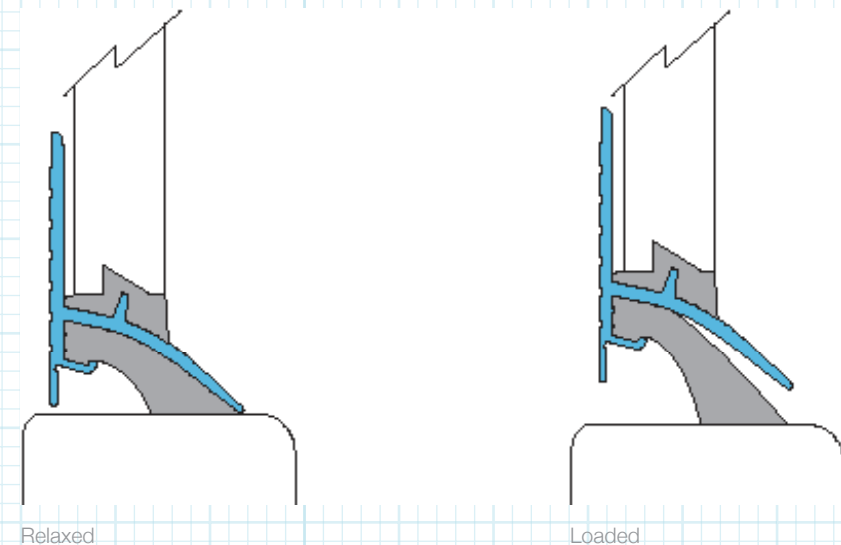

Internal corner profile

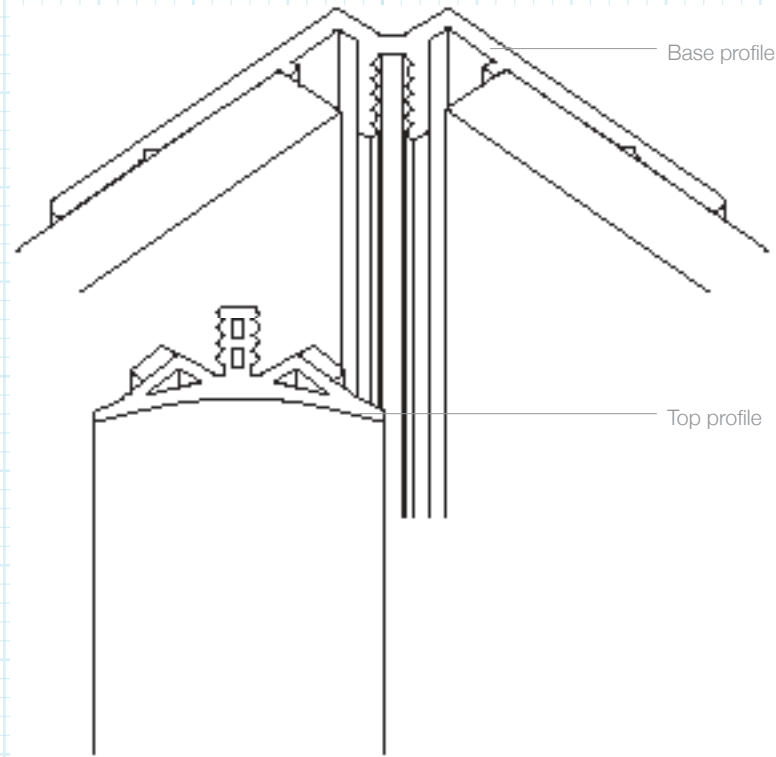

Features

- Patented design unique to Mermaid Panels.
- Silicone free high performance join.
- Allows for accurate panel measurement and cutting to ensure the join always overlaps in sealed areas.
- Utilises high performance exterior grade barrier tape to guarantee leak free joints.
- Allows for easy installation, as panels do not need to be fitted into corners in a specific sequence.
- Independently tested and certified by Trada (Timber Research and Development Association).

Verti-lock panel joint

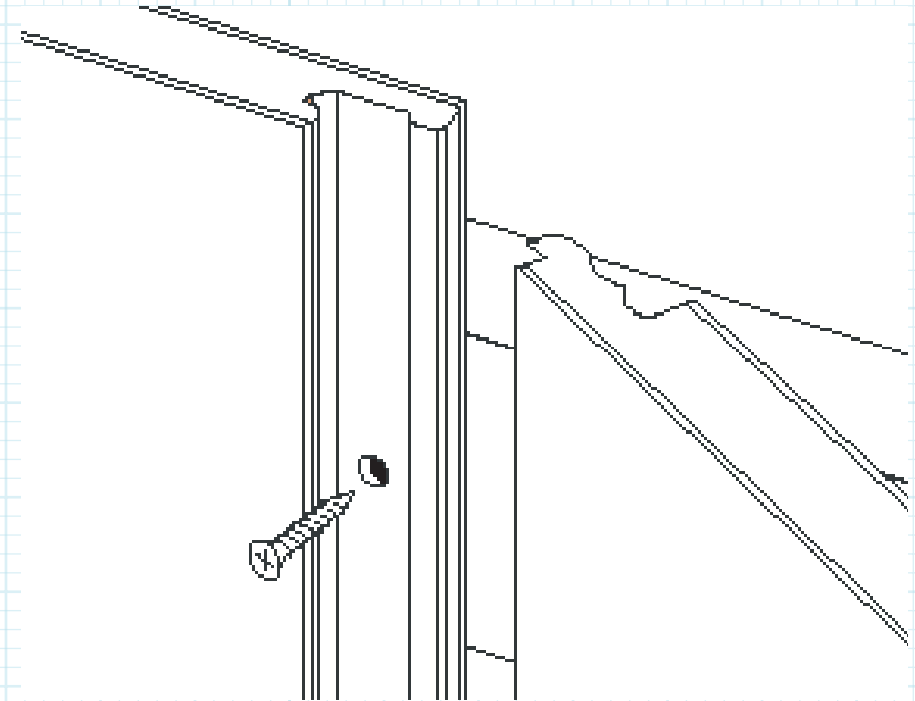

Features

- Engineered panel joint, on the edge of 585mm panels, to achieve locking fit.
- Allows for "secret" mechanical fixings to ensure secure fastening to the wall.
- Super-fine hairline joint.
- Will not open up over time.
- Requires hardly any silicone sealant to ensure water tightness.

About us

Mermaid Panels Ltd

DBC House
Laceby Business Park
Grimsby DN37 7DP
Tel 01472 279940
Fax 01472 752575
sales@mermaidpanels.com
www.mermaidpanels.com

Disclaimers

All colours are representative - we recommend you ring for a sample before ordering.

It's important to note with the Orchid patterns that, like traditional wallpaper, it's impossible to get the large panels to match perfectly next to each other when in situ.

Although most Mermaid panels can be fitted by any competent tradesperson, for glass our newest and most technically advanced product, we will supply or recommend a professional fitter to survey and install.

For 10 year guarantee information please visit: www.mermaidpanels.com

History

We've been designing and producing our shower and wall panels from our base in the North of England for the last 25 years.

In that time there have been many changes, but we've always been about one thing - panels. We've been the market leader and various innovations over the years have kept us there, now it's our glass panels which keep us at the top, but we won't rest on our laurels - we'll be updating our product range to keep us ahead of the game.

You can follow us on twitter and facebook to be first in line to know what we are up to. Links can be found on our website: www.mermaidpanels.com

Some of our earlier literature - we're proud of everything we have achieved, but on reflection, we're not sure about the use of the actual Mermaid!

